

AGDIS 100

DISINNESTO MECCANICO A COMANDO IDRAULICO
HYDRAULIC CONTROL MECHANICAL DISENGAGE SYSTEM

DISINNESTO DISENGAGE		AGDIS 100	AGDIS 100
Flangiatura ingresso Input flange version		S05 - albero 9	S05 - shaft type 9
Flangiatura uscita Output flange version		S1 - albero 7	S1 - shaft type 7
Coppia continua max Max. continuous torque	Nm	1000	
Coppia max di picco Max. peak torque	Nm	1250	
Pressione di pilotaggio Brake pilot pressure	max bar min bar	30 10	
Peso a secco Dry weight	kg	19,5	

	TIPO TYPE	TAGLIA SIZE	ENTRATA IN	USCITA OUT
Codice d'ordinazione ordering code	AGDIS	100	S05-9	S1-7

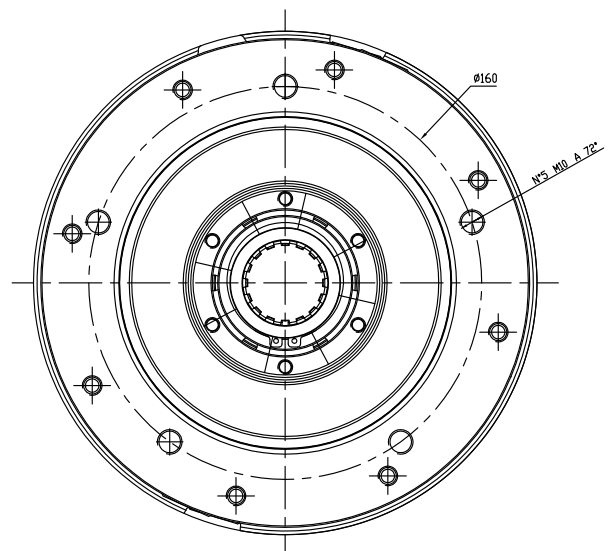
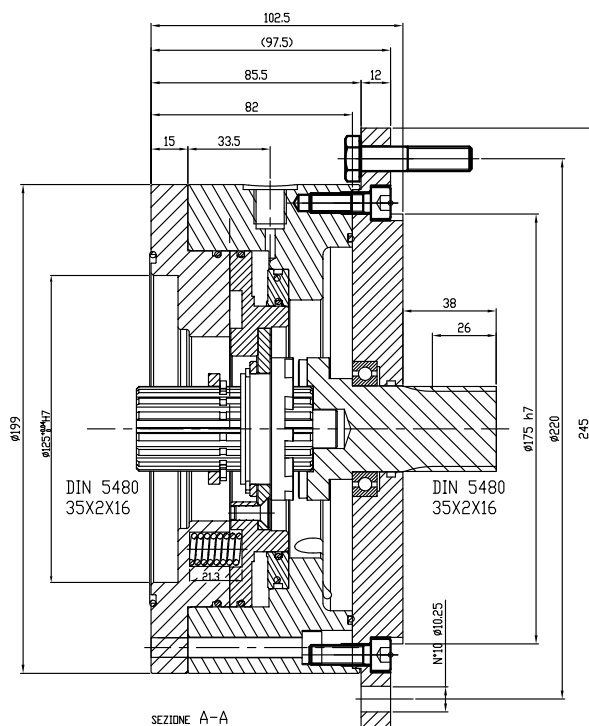

I dati specificati sono a puro scopo descrittivo e non devono essere interpretati come caratteristiche garantite in senso legale.
The specified data are for product description purpose only and must not be interpreted as warranted characteristics in a legal sense.